

Rea Paolo Tilche 1956

Sedia e sgabello

Materiali

STRUTTURA: acciaio verniciato a polvere color nero opaco.
SEDUTA E SCHIENALE: cuoio pieno fiore conciato al vegetale e tinto all'anilina color naturale.



+info:
<http://www.depadova.com/materials.pdf>

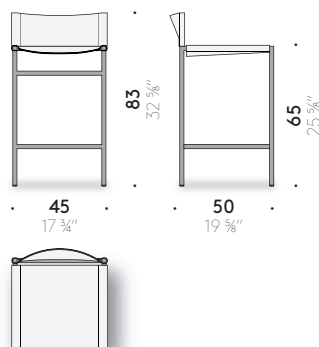
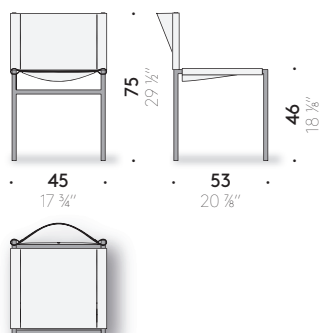

Rea Paolo Tilche 1956

Chair and stool

Materials

FRAME: matt black powder-coated steel.

SEAT AND BACKREST: full grain, vegetable- tanned aniline-dyed cowhide, in natural colour.



+info:

<http://www.depadova.com/materials.pdf>

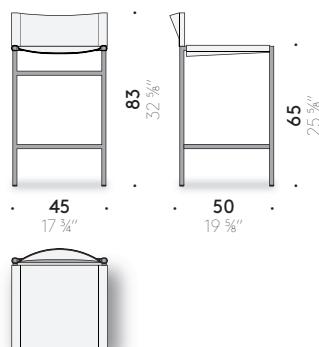
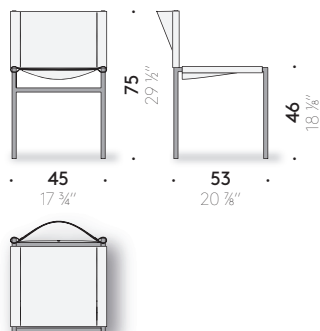

Rea Paolo Tilche 1956

Chaise et tabouret

Matériaux

STRUCTURE: acier peint noir mat à poudre.
ASSISE ET DOSSIER: cuir pleine fleur tanné au végétal et teinté à l'aniline, couleur naturelle.



+info:
<http://www.depadova.com/materials.pdf>

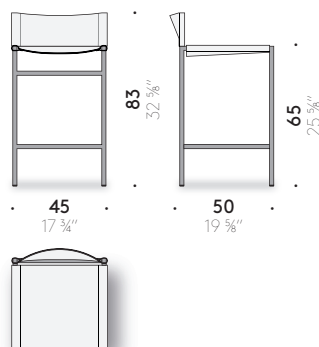
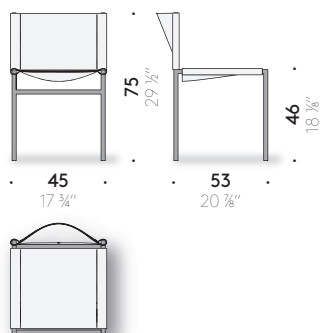

Rea Paolo Tilche 1956

Stuhl und Hocker

Materialien

GESTELL: Stahl mit Pulverlackierung, matt schwarz.

SITZ UND RÜCKENLEHNE: aus pflanzlich gegerbtem vollnarbigem und anilingefärbtem Leder, naturfarben.



+info:

<http://www.depadova.com/materials.pdf>

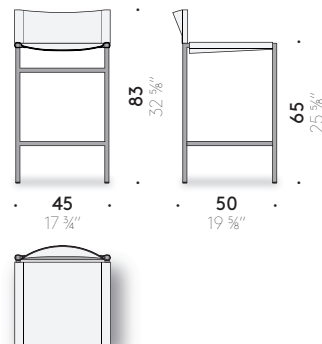
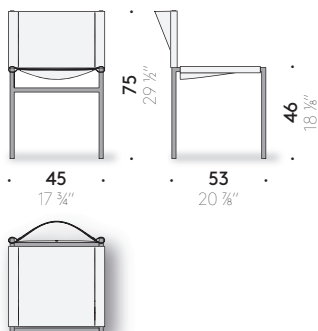

Rea Paolo Tilche 1956

Silla y taburete

Materiales

ESTRUCTURA: acero pintado en polvo color negro mate.
ASIENTO Y RESPALDO: cuero plena flor curtido al vegetal y teñido a la anilina color natural.



+info:
<http://www.depadova.com/materials.pdf>

